

PHILIPS

Headphones

6000 Series

TAH6206



User manual

Register your product and get support at
www.philips.com/support

Contents

1	Important safety instructions	2
	Hearing Safety	2
	General information	2

2	Your Wireless headphones	3
	What's in the box	3
	Overview of your wireless headphones	4

3	Get started	5
	Charge the headphones	5
	Pair the headphones with your mobile phone	5

4	Use your headphones	6
	Connect the headphones to a mobile phone	6
	Manage your calls and music	6
	Pair the headphones to the dongle transmitter	7
	Use on TV	7
	Use on PC	8
	Ear cushion replace	8

5	Technical data	9
---	----------------	---

6	Notice	10
	Declaration of conformity	10
	Disposal of your old product and battery	10
	Remove the integrated battery	10
	Compliance with EMF	10
	Environmental information	11
	Notice of compliance	11

7	Trademarks	12
---	------------	----

8	Frequently asked questions	13
---	----------------------------	----

1 Important safety instructions

Hearing Safety



Danger

- To avoid hearing damage, limit the time you use headphones at high volume and set the volume to a safe level. The louder the volume, the shorter the safe listening time is.

Be sure to observe the following guidelines when using your headset.

- Listen at reasonable volumes for reasonable periods of time.
- Be careful not to adjust the volume continuously upwards as your hearing adapts.
- Do not turn up the volume so high that you can't hear what's around you.
- You should use caution or temporarily discontinue use in potentially hazardous situations.
- Excessive sound pressure from earphones and headphones can cause hearing loss.
- Using headphones with both ears covered while driving is not recommended and may be illegal in some areas while driving.
- For your safety, avoid distractions from music or phone calls while in traffic or other potentially dangerous environments.

General information

To avoid damage or malfunction:



Caution

- Do not expose headphones to excessive heat
- Do not drop your headphones.
- Headphones shall not be exposed to dripping or splashing.
- Do not allow your headphones to be submerged in water.
- Do not use any cleaning agents containing alcohol, ammonia, benzene, or abrasives.
- If cleaning is required use a soft cloth, if necessary dampened with a minimum amount of water or diluted mild soap, to clean the product.
- The integrated battery shall not be exposed to excessive heat such as sunshine, fire or the like.
- Replacement of a battery with an incorrect type that can defeat a safeguard;
- Disposal of a battery into fire or a hot oven, or mechanically crushing or cutting of a battery, that can result in an explosion;
- Leaving a battery in an extremely high temperature surrounding environment that can result in an explosion or the leakage of flammable liquid or gas;
- A battery subjected to extremely low air pressure that may result in an explosion or the leakage of flammable liquid or gas.
- Never use your headphones when you are operating a motor vehicle, riding a bicycle, running or walking in traffic areas. It is dangerous and illegal in many places.

About operating and storage temperatures and humidity

- Operating temperature: 0°C (32°F) to 40°C (104°F)
- Storage temperature: -10°C (14°F) to 45°C (113°F)
- Operating humidity: 8% - 90% RH (No condensation)
- Storage humidity: 5% - 90% RH (No condensation)
- Maximum operating altitude: 3000m
- Battery life may be shorter in high or low temperature conditions.

2 Your Wireless headphones

Congratulations on your purchase, and welcome to Philips! To fully benefit from the support that Philips offers, register your product at www.philips.com/support.

With this Philips headphones, you can:

- Enjoy convenient wireless TV show;
- Enjoy and control wireless music.

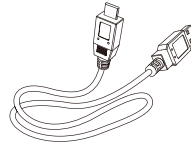

USB Type-C charging cable

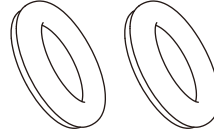

Cloth ear pad (1 pair)

What's in the box

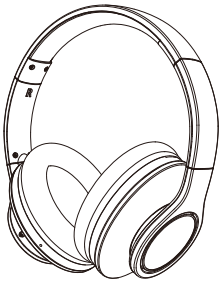

Headphones



USB dongle

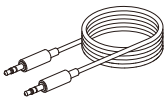

3.5 mm audio cable



Quick start guide



Global Warranty



Safety leaflet

Overview of your wireless headphones

Headphones

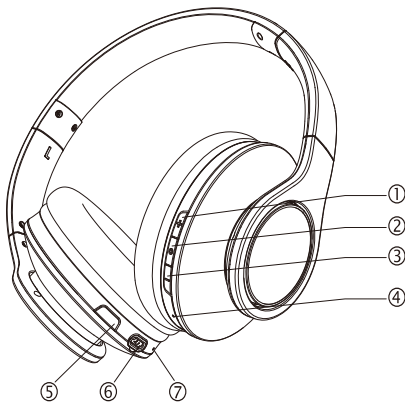

- ① Volume +
- ② Multi-function button (MFB)
- ③ Volume -
- ④ LED (Signal indicator, Blue/White)
- ⑤ Dongle/Mobile selection button (D/M) button
- ⑥ Type-C socket (for charging)
- ⑦ LED (Charging indicator, Amber/White)

USB Dongle

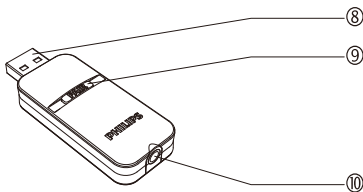

- ⑧ USB plug
- ⑨ PAIR button
- ⑩ Aux jack

3 Get started

Charge the headphones

Note

- Charge the headphones with the supplied USB Type-C cable for two hours for optimum battery capacity and lifetime.
- Use only the original USB Type-C charging cable to avoid any damage.
- It is highly recommended to Power Off the headphones before battery charging.

Plug the USB Type-C plug of the cable to the headphones, another end plug into a powered USB port. The LED turns Amber during charging and turns white when the headset is fully charged.

Tip

- Normally, a full charge takes 2 hours.

Pair the headphones with your mobile phone

Before using the headphones with your mobile phone for the first time, pair it with the mobile phone. A successful pairing establishes a unique encrypted link between the headset and the mobile phone.

- 1 Make sure that the mobile phone is turned on and its Bluetooth feature is activated.
- 2 Make sure that the headphones is charged and turned off.
- 3 Press and hold “MFB” Button for 4 seconds until the LED starts flashing white and blue alternately. The headphones is in pairing mode, which lasts five minutes.
- 4 The list of Bluetooth from the mobile phone shows "TAH6206", just simply select "TAH6206" to pair with the headphones.



TAH6206

4 Use your headphones

Connect the headphones to a mobile phone

- 1 Turn on your mobile phone.
- 2 Press and hold the "MFB" button to turn the headphones on, then the Blue LED flashes, the headphone is reconnected to the last connected device automatically. If the last one is not available, the headphones tries to reconnect to the second last connected device.

Manage your calls and music

On/off

Task	Button	Operation
Turn the headphones on	MFB	Press and hold for 2 seconds.
Turn the headphones off	MFB	Press and hold for 4 seconds. ↳ The blue LED is on and fades out.
BT Pairing Mode	MFB	Power On and keep Press and hold 4s
Dongle Pairing Mode	D/M	Press and hold 2s

Music control

Task	Button	Operation
Play or pause music	MFB	Press once
Volume Up	+	Press once
Volume Down	-	Press once
Next track	+	Press and hold 2s
Previous track	-	Press and hold 2s

Call control

Task	Button	Operation
Pick up/ hang up a call	MFB	Press once
Reject call	MFB	Press and hold 2s
Recall	MFB	Press twice

Voice Assistant

Task	Button	Operation
Google/Siri Trigger	MFB	Press twice

Pair the headphones to the dongle transmitter

Plug the dongle to the USB jack of TV or PC. Press and hold the “PAIR” button on the dongle for 4 seconds. The blue LED will flashing.

Press and hold “D/M” button on the headphones for 4 seconds. The LED will flashing blue and white. When pairing is successful, the LED will steady white on the headphones.

Use on TV

For connect to TV with USB audio:

- ↳ When the dongle and headphones are paired, press the “PAIR” button 1x on the dongle to select USB mode. The LED will steady blue on the dongle. Now you can listen the TV program on the headphones.



Remark

- You may need to select the USB out on the TV manual. Please refer to your TV user manual.

For connect to TV without USB audio:

- ↳ Plug the one end of 3.5mm to 3.5mm stereo cable to the USB dongle 's aux jack, and plug the other end of the cable to the TV's phone-in jack.
- ↳ Press the “PAIR” button 1x on the dongle to select AUX mode. The blue LED will 1 second on and 2 seconds off. Now you can listen the TV program on the headphones.

Switch the headphones connection between dongle and mobile phone:

- ↳ Make sure the headphones has paired the dongle and mobile phone individually.

Press the “D/M” button on the headphones to select connection to dongle or mobile phone:

- 1 Connect to dongle: headphones LED steady white.
- 2 Connect to mobile phone: head-phone LED steady blue.

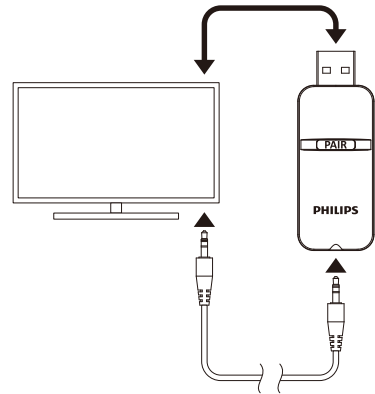

USB Dongle

Task	Button	Operation
Power On		When plug into USB port ,the Dongle will power on automatically
Power Off		When pull out the USB port, the Dongle will power off
USB / AUX mode	PAIR	Press once
Enter Dongle pairing mode	PAIR	Press and hold 2s

Use on PC

Plug the dongle to a USB port from PC.

- ↳ When the dongle and headphones are paired, press the "PAIR" button 1x on the dongle to select USB mode. The LED will steady blue on the dongle. Now you can listen the PC sound on the headphones.

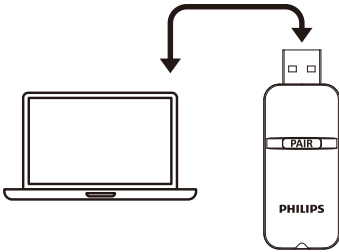

Remark

- If computer has Bluetooth function, headphones can connect to computer without USB Dongle. But it cannot support low latency performance.

Ear cushion replace

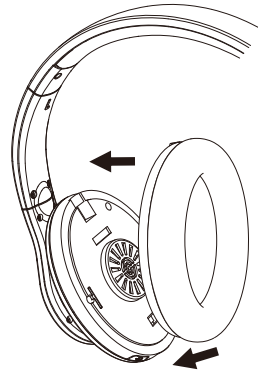
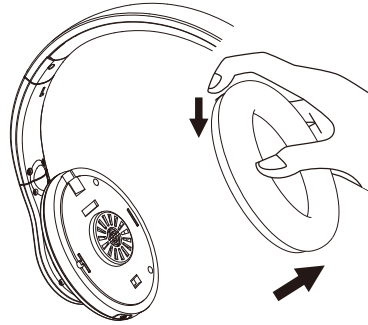

5 Technical data

USB dongle

- Frequency range: 2.402-2.480 GHz
- Transmitter power: < 10 dBm
- Operating range(paired with TAH6206 headset):
Up to 20 meters (66 feet)

Headset

- Music time: 18 hours
- Talk time: 20 hours
- Standby time: 150 hours
- Fast Charging time: 15 minutes can play 1 hour
- Charging time: 2 hours
- Rechargeable lithium polymer battery (750 mAh)
- Bluetooth version: 5.1
- Compatible Bluetooth profiles:
 - HFP (Hands-Free Profile)
 - A2DP (Advanced Audio Distribution Profile)
 - AVRCP (Audio Video Remote Control Profile)
- Supported audio codec: SBC
- Frequency range: 2.402-2.480 GHz
- Transmitter power: < 10 dBm
- Operating range(paired with mobile phone): Up
to 10 meters (33 feet)
- Auto power off
- Type-C USB port for charging
- Supports SBC



Tip

For further product support, please visit
www.philips.com/support.

6 Notice

Declaration of conformity

Hereby, MMD Hong Kong Holding Limited declares that this product is in compliance with the essential requirements and other relevant provisions of Directive 2014/53/EU. You can find the Declaration of Conformity on www.p4c.philips.com.

Disposal of your old product and battery



Your product is designed and manufactured with high quality materials and components, which can be recycled and reused.



This symbol on a product means that the product is covered by European Directive 2012/19/EU.



This symbol means that the product contains a built-in rechargeable battery covered by European Directive 2013/56/EU which cannot be disposed of with normal household waste. We strongly advise you to take your product to an official collection point or a Philips service centre to have a professional remove the rechargeable battery. Inform yourself about the local separate collection system for electrical and electronic products and rechargeable batteries. Follow local rules and never dispose of the product and rechargeable batteries with normal household waste. Correct disposal of old products and

rechargeable batteries helps prevent negative consequences for the environment and human health.

Remove the integrated battery

If there is no collection/recycling system for electronic products in your country, you can protect the environment by removing and recycling the battery before disposing the headphones.

- Make sure the headset is disconnected from the charging case before removing the battery.

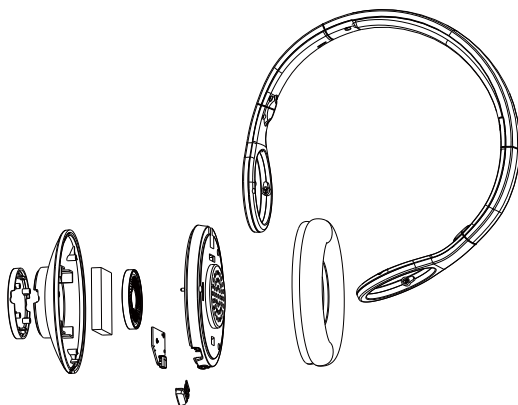

Compliance with EMF

This product complies with all applicable standards and regulations regarding exposure to electromagnetic fields.

Environmental information

All unnecessary packaging has been omitted. We have tried to make the packaging easy to separate into three materials: cardboard (box), polystyrene foam (buffer) and polyethylene (bags, protective foam sheet.)

Your system consists of materials which can be recycled and reused if disassembled by a specialized company. Please observe the local regulations regarding the disposal of packaging materials, exhausted batteries and old equipment.

Notice of compliance

The device complies with the FCC rules, Part 15. Operation is subject to the following two conditions:

1. **This device may not cause harmful interference, and**
2. **This device must accept any interference received, including interference that may cause undesired operation.**

FCC rules

This equipment has been tested and found to comply with the limits for a Class B digital device, pursuant to part 15 of the FCC Rules. These limits are designed to provide reasonable protection against harmful interference in a residential installation. This equipment generates, uses and can radiate radio frequency energy and, if not installed and used in accordance with the instruction manual, may cause harmful interference to radio communications. However, there is no guarantee that interference will not occur in a particular installation. If this equipment does cause harmful interference to radio or

television reception, which can be determined by turning the equipment off and on, the user is encouraged to try to correct the interference by one or more of the following measures:

- Reorient or relocate the receiving antenna.
- Increase the separation between equipment and receiver
- Connect the equipment into an outlet on a circuit different from that to which the receiver is connected.
- Consult the dealer or an experienced radio/TV technician for help.

FCC Radiation Exposure Statement:

This equipment complies with FCC radiation exposure limits set forth for an uncontrolled environment.

This transmitter must not be co-located or operating in conjunction with any other antenna or transmitter.

Caution: The user is cautioned that changes or modifications not expressly approved by the party responsible for compliance could void the user's authority to operate the equipment.

Canada:

This device contains licence-exempt transmitter(s)/receiver(s) that comply with Innovation, Science and Economic Development Canada's licence-exempt RSS(s). Operation is subject to the following two conditions: (1) this device may not cause harmful interference, and (2) This device must accept any interference received, including interference that may cause undesired operation of the device.

CAN ICES-3(B)/NMB-3(B)

IC Radiation Exposure Statement:

This equipment complies with Canada radiation exposure limits set forth for uncontrolled environments.

This transmitter must not be co-located or operating in conjunction with any other antenna or transmitter.

7 Trademarks

Bluetooth

The Bluetooth® word mark and logos are registered trademarks owned by Bluetooth SIG, Inc. and any use of such marks by Top Victory Investment Limited is under license. Other trademarks and trade names are those of their respective owners.

Siri

Siri is a trademark of Apple Inc., registered in the U.S. and other countries.

Google

Google and Google Play are trademarks of Google LLC.

8 Frequently asked questions

My Bluetooth headset does not turn on.

The battery level is low. Charge the headset.

I cannot pair my Bluetooth headset with my Bluetooth device.

The Bluetooth is disabled. Enable the Bluetooth feature on your Bluetooth device and turn on the Bluetooth device before you turn on the headset.

How to reset the headphones.

If the headphone is no response during operation or can not turn on, push the “MFB” and “Volume +” button simultaneously for a second.

I hear but cannot control music on my Bluetooth device (e.g. play/pause/skip forward/backward).

Make sure the Bluetooth audio source supports AVRCP (see ‘Technical data’ on page 8).

The volume level of the headset is too low.

Some Bluetooth devices cannot link the volume level with the headset through volume sync. In this case, you have to adjust the volume on your Bluetooth device independently to achieve an appropriate volume level.

The Bluetooth device cannot find the headset.

- The headset may be connected to a previously paired device. Turn o the connected device or move it out of range.
- Pairing may have been reset or the headset has been previously paired with another device. Pair the headset with the Bluetooth device again as described in the user manual. (see ‘Pair the headset with your Bluetooth device at the first time’ on page 5).

My Bluetooth headset is connected to a Bluetooth stereo enabled mobile phone, but music only plays on the mobile phone speaker. Refer to the user manual of your mobile phone. Select to listen to music through the headset.

The audio quality is poor and crackling noise can be heard.

- The Bluetooth device is out of range. Reduce the distance between your headset and Bluetooth device, or remove obstacles between them.
- Charge your headset.

The audio quality is poor when streaming from the mobile phone is very slow, or audio streaming does not work at all.

Make sure your mobile phone not only supports (mono) HFP but also supports A2DP and is BT4.0x (or higher) compatible (see ‘Technical data’ on page 8).

For further support, visit www.philips.com/support.



Philips and the Philips Shield Emblem are registered trademarks of Koninklijke Philips N.V. and are used under license. This product has been manufactured by and is sold under the responsibility of MMD Hong Kong Holding Limited or one of its affiliates, and MMD Hong Kong Holding Limited is the warrantor in relation to this product.

