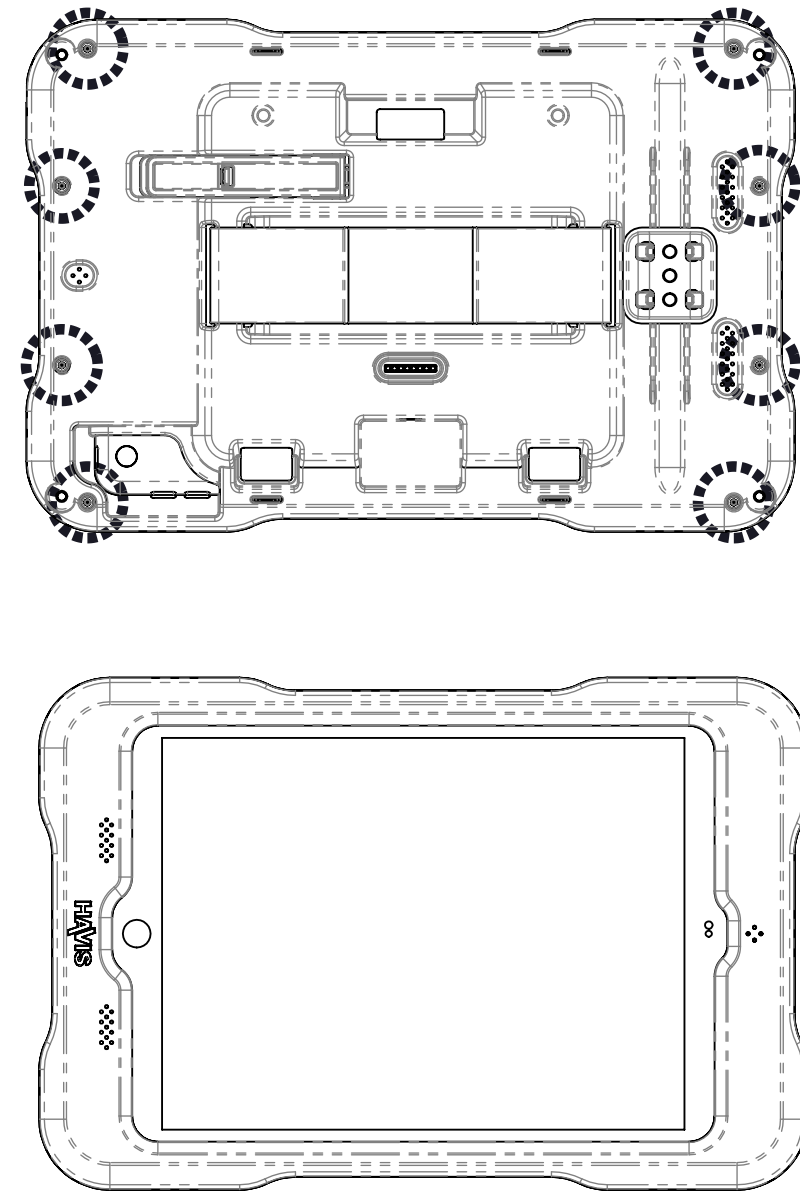
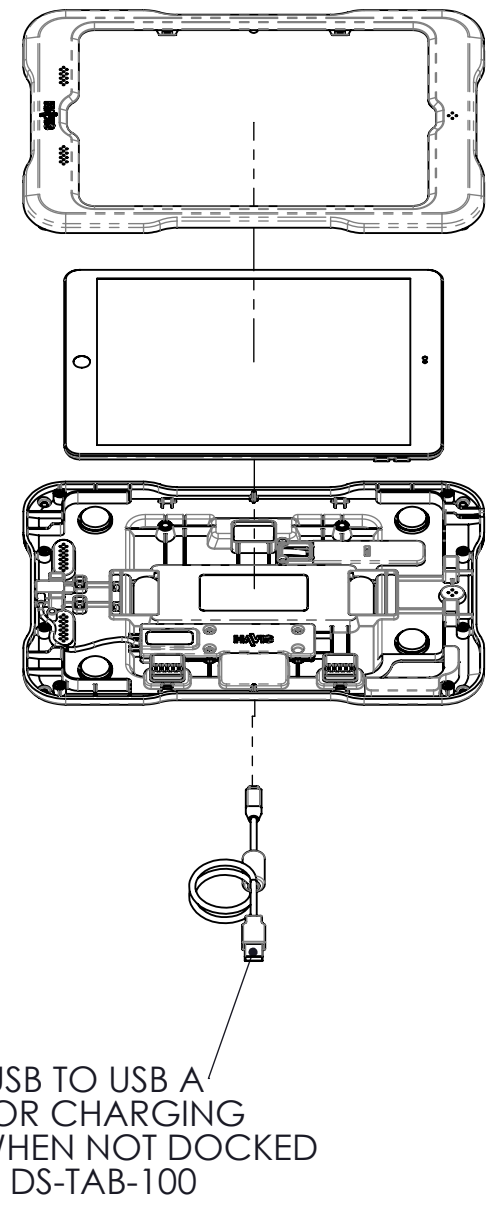
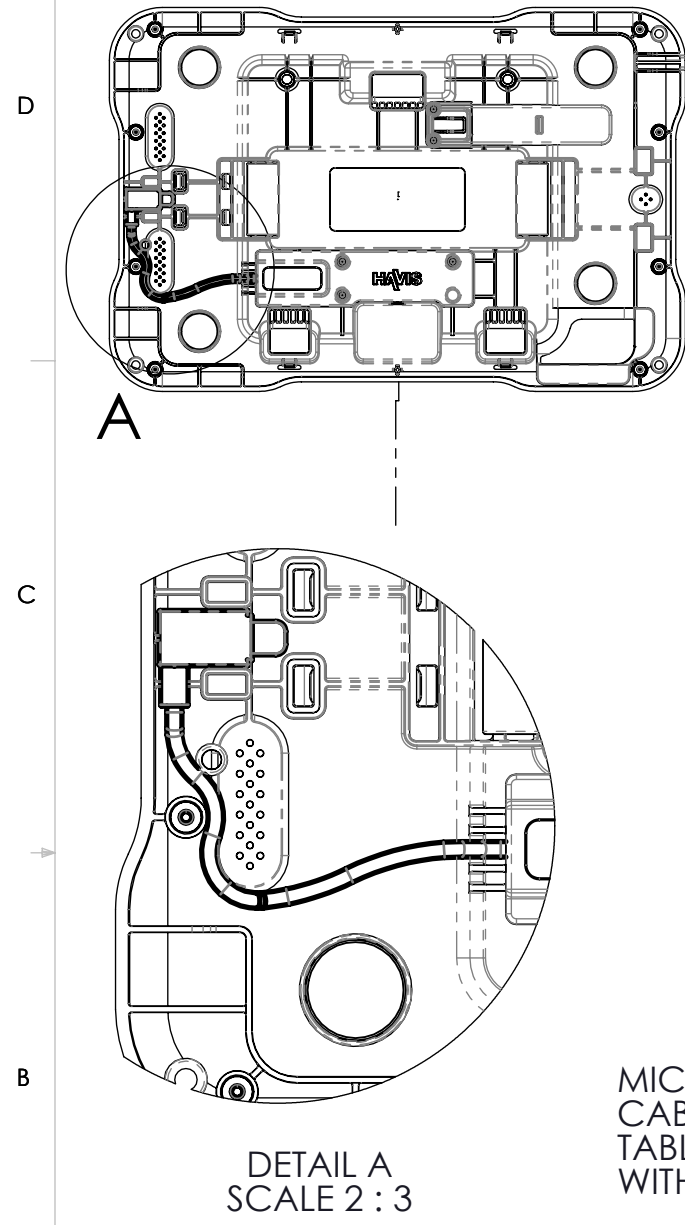


IMAGE 1

IMAGE 2

IMAGE 3

**INSTALLATION INSTRUCTIONS:**



1. Note the cable routing detailed in Image 1, Detail A.
2. Insert the connector from the Protective Case into the Apple iPad (7th Gen).
3. Place the iPad into the Rear Protective Case and ensure that the cable routing matches that shown in Detail A. Be careful not to pinch the cable.
4. Place Front Protective Case onto the rear, noting that the Havis logo should be positioned on the bottom side (connector side) of the iPad. Ensure that the cable is not pinched when placing the two halves together.
5. Your Protective Case includes four (4) snapfits near the center of the case. Apply light pressure until all the snaps are interlocked.
6. Holding the two halves of the Protective Case together carefully turn the Protective Case over.
7. Fasten all eight (8) of the M2.5 x 6mm screws (Item #1) with the supplied T8 torx bit (Item #2) into locations shown in Image 3. Torque to 4 in-lbs +/- 10%. Do not overtighten screws.

**NOTE:** Hardware kit includes extra screws in the event of loss or damage.

**HARDWARE KIT CONTENTS**

ITEM #	DESCRIPTION	QTY.	FINISH	DRIVE STYLE/ SIZE
1	THREAD-FORMING SCREW, ROUND WASHER HEAD, M3.0 STS+ THREAD, 6MM LONG, STEEL,	12	ZINC-NICKEL PLATED, BLACK	T8 TORX
2	T-8 PIN-IN TORX BIT	1	N/A	1/4" HEX

**DRAWING NUMBER:  
TC-107\_INST\_01-20**

**WARNING:** ALL HAVIS INC. PRODUCTS ARE DESIGNED WITH SAFETY OF USE AND INSTALLATION IN MIND. HOWEVER, IT IS THE SOLE RESPONSIBILITY OF THE OWNER/OPERATOR OF A VEHICLE USING HAVIS INC. MOUNTING AND DOCKING EQUIPMENT, TO INSURE THAT THE EQUIPMENT IS INSTALLED SO THAT IT WILL NOT INTERFERE WITH VEHICLE OPERATION, INTERFERE WITH SAFETY DEVICES, OBSTRUCT VIEW OF DRIVING CONDITIONS, OR IN ANY WAY DEGRADE OCCUPANT SAFETY. IMPROPER INSTALLATION CAN CAUSE SERIOUS INJURY IN THE EVENT OF AN ACCIDENT. INSTALLATION SHOULD ONLY BE PERFORMED BY QUALIFIED PROFESSIONALS. COMPUTERS AND MOTION DEVICES MUST BE MOVED TO AND STOWED/SECURED IN THEIR SAFE DRIVING POSITIONS BEFORE OPERATING VEHICLE.

PRODUCT DESCRIPTION  
**INSTALLATION INSTRUCTIONS FOR TC-107,  
iPad (7th GEN) PROTECTIVE COVER**

PRODUCT I.D. **TC-107**      DATE **01-17-20**

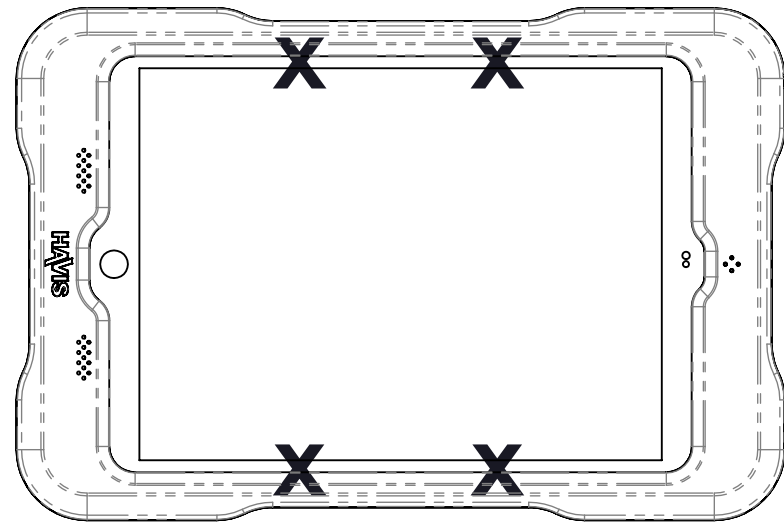
PRODUCT NAME  
**INSTALLATION INSTRUCTIONS FOR TC-107**

**HAVIS**  
1-800-524-9900  
WWW.HAVIS.COM

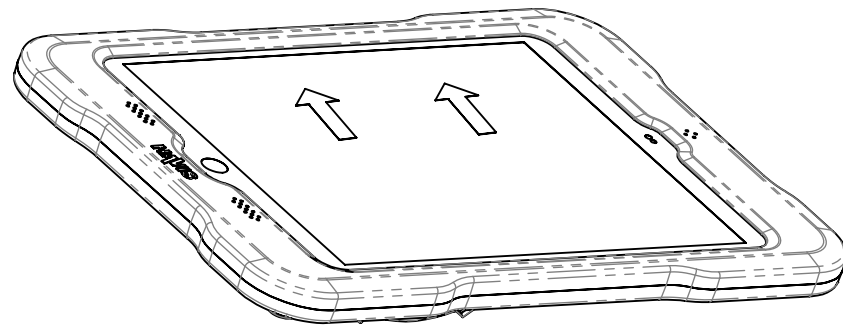
WEIGHT: (LBS) **1.573**  
REV. DATE **01-20**

# REMOVING TABLET FROM PROTECTIVE CASE:

1. Remove all eight (8) of the screws that secure the front and back case together. Reference Image 3 of the installation instructions.
2. Protective case contains four snap fits that must be detached to remove the front cover. Image 1 shows the locations of the snap fits.
3. Detach the snap fits on one side first applying light pressure on the snap fit locations in the directions indicated to detach the snaps (Reference Image 2).
4. While maintaining light pressure lift up the one side of the case to completely detach the snaps.
5. Repeat steps 3 and 4 to release the snaps on the opposite side. Once ALL snap fits are detached you can then remove the front case.
6. Detach the connector from the tablet.
7. Tablet can now be removed from the protective case.

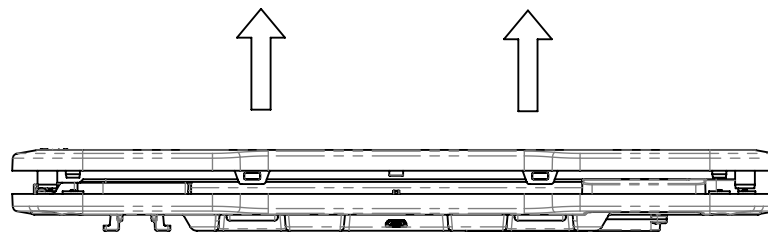


**IMAGE 1**  
LOCATION OF SNAP FITS



**IMAGE 2**

APPLY LIGHT PRESSURE ON LOCATION OF SNAP FITS TO UNHINGE THEM, THEN LIFT UP TO DETACH THE ONE SIDE.  
REPEAT ON OPPOSITE SIDE.



**IMAGE 3**

**DRAWING NUMBER:**  
**TC-107\_INST\_01-20**

**WARNING:** ALL HAVIS INC. PRODUCTS ARE DESIGNED WITH SAFETY OF USE AND INSTALLATION IN MIND. HOWEVER, IT IS THE SOLE RESPONSIBILITY OF THE OWNER/OPERATOR OF A VEHICLE USING HAVIS INC. MOUNTING AND DOCKING EQUIPMENT, TO INSURE THAT THE EQUIPMENT IS INSTALLED SO THAT IT WILL NOT INTERFERE WITH VEHICLE OPERATION, INTERFERE WITH SAFETY DEVICES, OBSTRUCT VIEW OF DRIVING CONDITIONS, OR IN ANY WAY DEGRADE OCCUPANT SAFETY. IMPROPER INSTALLATION CAN CAUSE SERIOUS INJURY IN THE EVENT OF AN ACCIDENT. INSTALLATION SHOULD ONLY BE PERFORMED BY QUALIFIED PROFESSIONALS. COMPUTERS AND MOTION DEVICES MUST BE MOVED TO AND STOWED/SECURED IN THEIR SAFE DRIVING POSITIONS BEFORE OPERATING VEHICLE.

PRODUCT DESCRIPTION

**INSTALLATION INSTRUCTIONS FOR TC-107,  
iPad (7th GEN) PROTECTIVE COVER**

PRODUCT I.D. <b>TC-107</b>	DATE <b>01-17-20</b>
-------------------------------	-------------------------

PRODUCT NAME  
**INSTALLATION  
INSTRUCTIONS FOR TC-107**

**HAVIS**  
1-800-524-9900  
WWW.HAVIS.COM

WEIGHT: (LBS) <b>1.573</b>
REV. DATE 01-20